

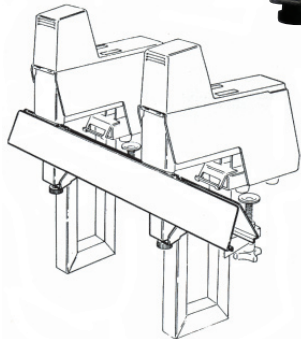

STAPLERS AND ACCESSORIES

W106-K Group Stapling Kit

Item ID: W106-K



- Designed for the Rapid 106 and allows for multi-stapling
- Operate two or more Rapid 106 staplers side by side with one foot switch
- Attached by optic cable
- Runner only accomodates saddle stapling

Includes...

- Saddle runner with two brackets
- Optic cable
- Two small anvils

Specifications

- Minimum distance between staples: 2-1/2"
- Maximum distance between staples: 15"
- Actual weight: 3 lbs
- Shipping weight: 4 lbs
- Ships via: UPS